

Unico System Grounding

1.0 Power Components

The diagram below shows recommended grounding for power section components of a typical Unico system.

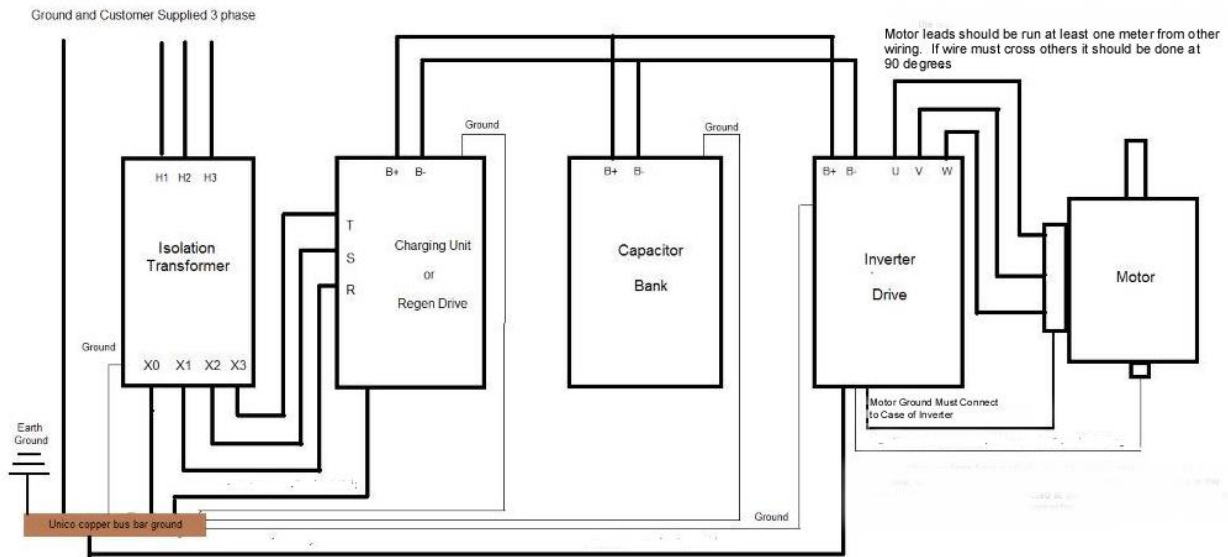

It is important that all high power leads be run in their own conduits, at least one meter away from other conductors. Any crossings of wires should be done at 90 degrees. It is important that the motor ground be terminated at the chassis of the inverter. From there, a connection to bus should be made. But there should not be a direct connection between the motor and the bus bar.

2.0 Encoder Ground Connections

2.1 Non Isolated Encoder Grounding

There are two grounding methods that are used with Unico encoders. Which method is used depends on if the encoder is isolated or non-isolated. An isolated encoder uses a coupling that has an insulator inserted so there is no electrical connection by way of the coupling. Also, the encoder mounts on an insulated flange so there is no conductivity between the encoder body and its mount.

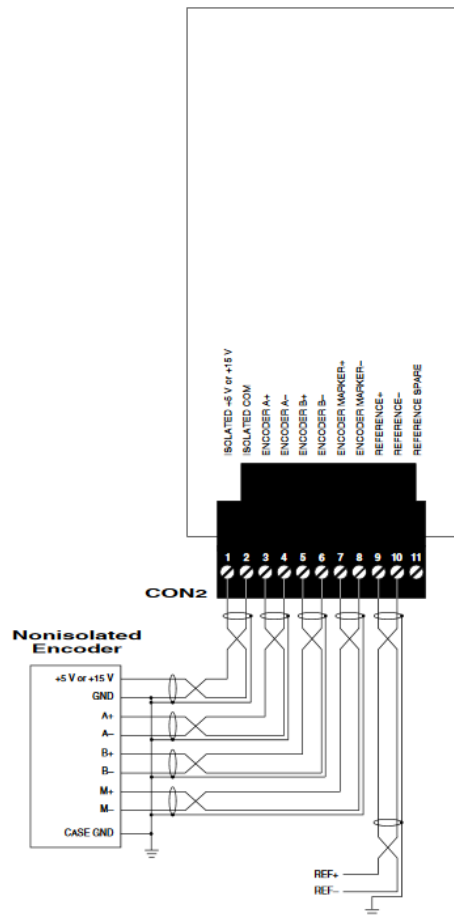

With a non insulated encoder, the shield and chassis of the encoder are grounded at the encoder. There are no chassis or earth grounds at the DSP encoder interface.

2.2 Isolated Encoder Grounding

The diagram below shows an isolated encoder. In this case, the shield and chassis ground of the encoder are not tied at the encoder location. Instead, these conductors make the run to the drive where there is a chassis ground connection made.

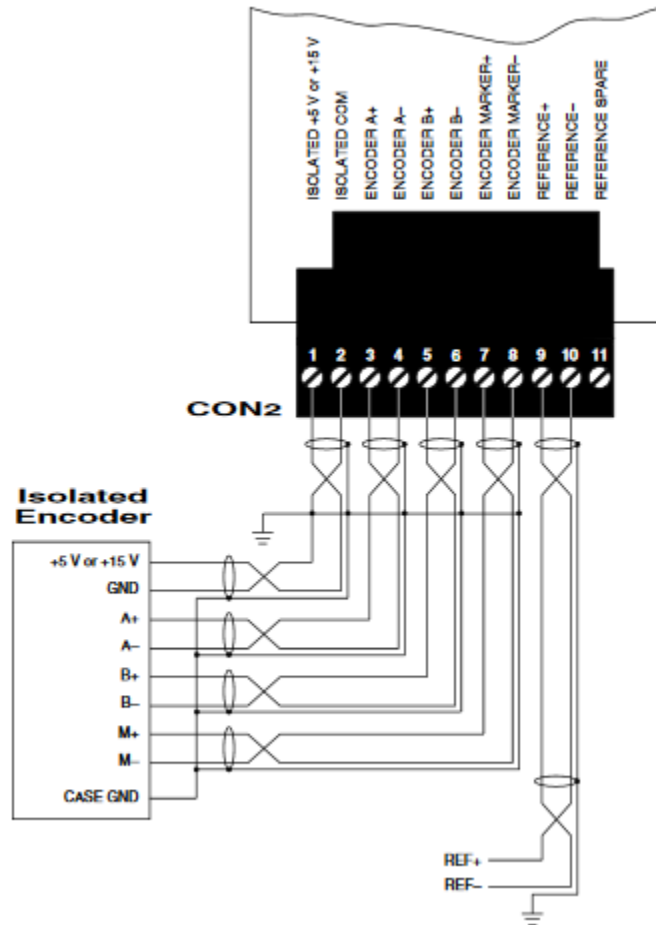

While the power component and encoder grounds tend to be the most important, proper grounding is important elsewhere. Please refer to the Unico 2400 or 1100 manual for recommendations for grounding of other connections.